

ALFAGOMMA One-Piece AlfaCrimp Fittings – S Series

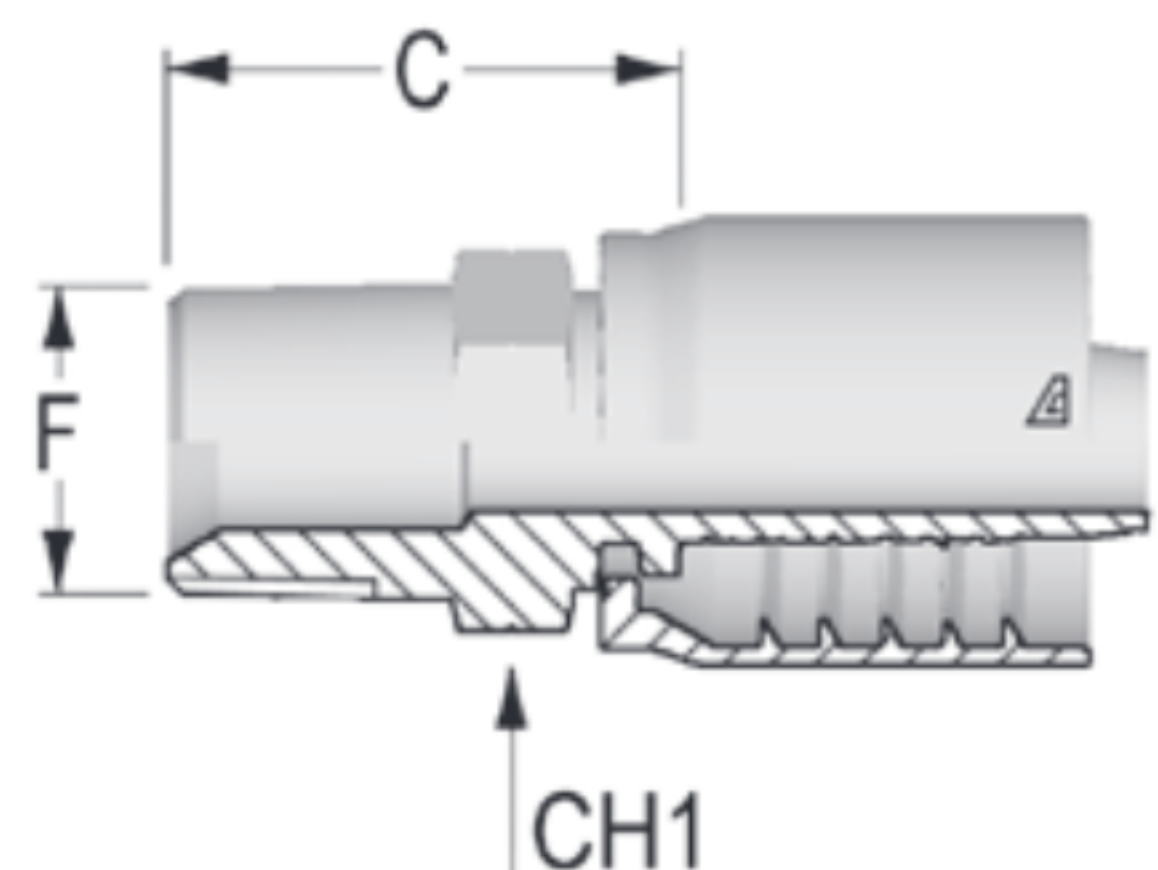

NPTF MALE 60° SEAT

**Preliminary Data*

Part Number	Dash Size	Hose ID Size		F Thread		C Cut-Off Factor (mm)	Hex Dia. CH1 (in)	Weight (lbs/each)
		(in)	(mm)	Dash Size	Size (in) - TPI			
S-1212-MNPT	12	3/4	19.1	12	3/4-14	35.5	27	0.60
S-1616-MNPT	16	1	25.4	16	1-11 1/2	44.4	36	1.06
S-2020-MNPT	20	1 1/4	31.8	20	1 1/4-11 1/2	50.9	46	1.68
S-2424-MNPT	24	1 1/2	38.1	24	1 1/2-11 1/2	54.5	50	2.37
S-3232-MNPT	32	2	50.8	32	2-11 1/2	53.7	65	4.22

View Up To Date Info



◀ SCAN OR VISIT
KOA.link/S-MNPT

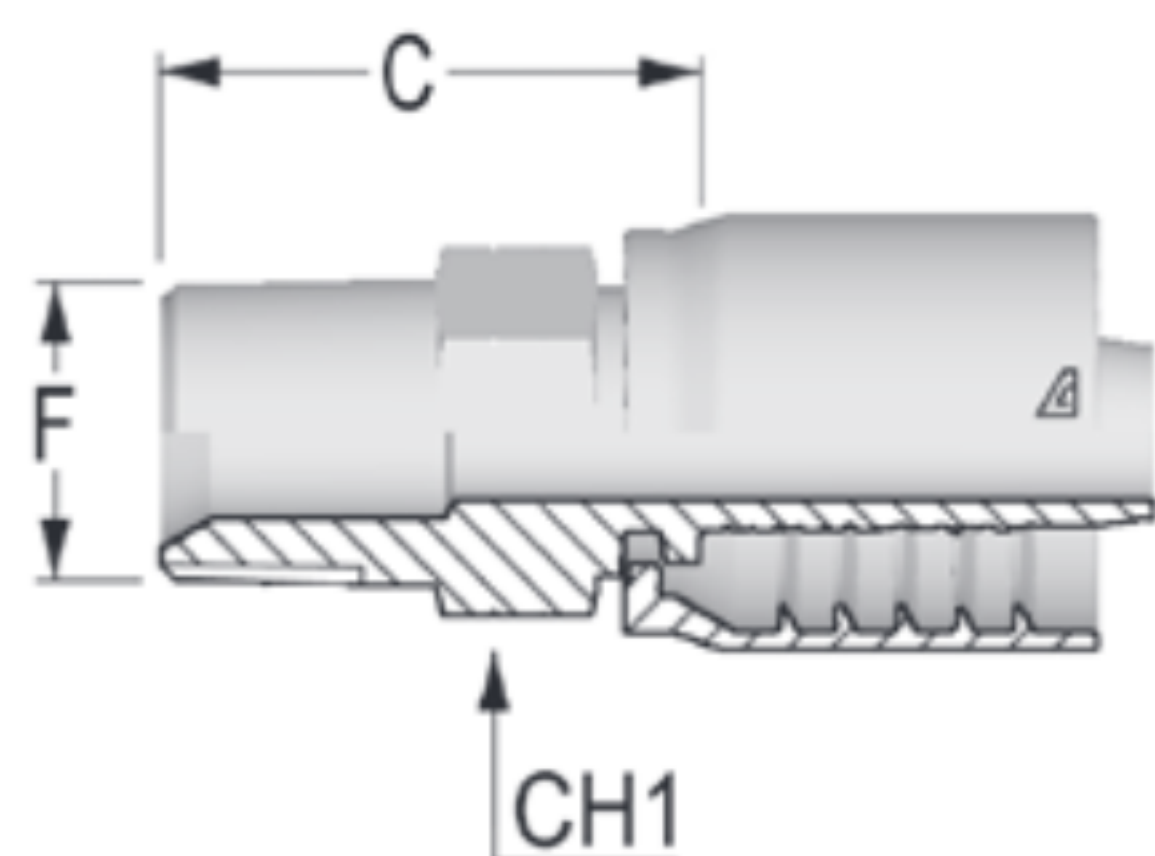

API MALE NPT

Part Number	Dash Size	Hose ID Size		F Thread		C Cut-Off Factor (mm)	Hex Dia. CH1 (in)	Weight (lbs/each)
		(in)	(mm)	Dash Size	Size (in) - TPI			
S-3232-MAPI	32	2	50.8	32	2-11 1/2	105.7	65	5.58

View Up To Date Info



◀ SCAN OR VISIT
KOA.link/S-MAPI

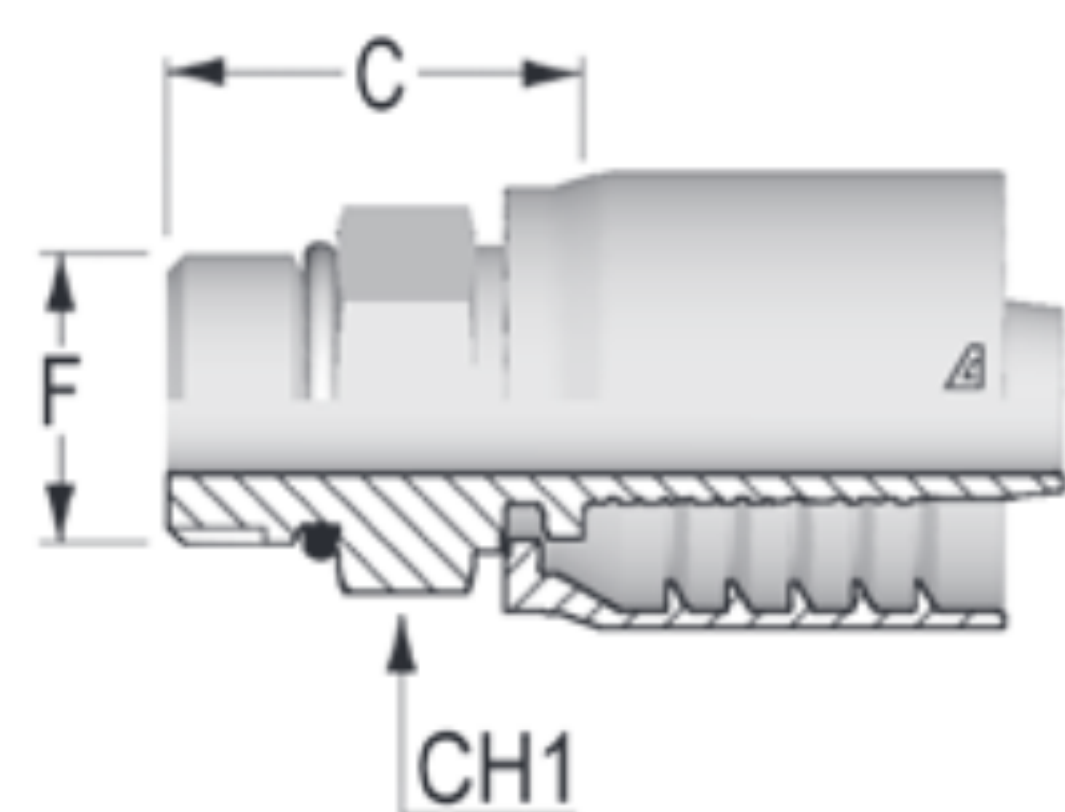

SAE MALE O-RING BOSS

**Preliminary Data*

Part Number	Dash Size	Hose ID Size		F Thread		C Cut-Off Factor (mm)	Hex Dia. CH1 (in)	Weight (lbs/each)
		(in)	(mm)	Dash Size	Size (in) - TPI			
S-1212-MORB	12	3/4	19.1	12	3/4-14	32.6	32	0.65
S-2020-MORB	20	1 1/4	31.8	20	Pending	Pending	Pending	1.55

View Up To Date Info



◀ SCAN OR VISIT
KOA.link/S-MORB

Because we continually examine ways to improve our products, we reserve the right to alter specifications or discontinue products without prior notice.