

## Expansion Joints

### HTSRF Series

#### Single Sphere Rubber Expansion Joints

**VIEW ONLINE**



SCAN FOR INFO

or visit

[KOA.link/HTSRF](http://KOA.link/HTSRF)

#### FEATURES AND ADVANTAGES

- Excellent ability to absorb vibration and sound.
- Allows for four-way movement.
- Withstands high pressure.
- Easy installation using either floating flanges or threaded unions.
- Excellent for use with moderate chemicals, most oils, fats, grease, and many solvents.
- A retention ring is supplied with all double sphere flanged expansion joints.

#### MATERIAL SPECIFICATIONS

- Nylon fabric-reinforced neoprene body.
- HTSRF and HTDRF series supplied with forged carbon steel flanges.
- HTDRU supplied with ductile iron plated pipe unions.
- Flanges meet ANSI B16.56 and ASTM A-105 specifications.

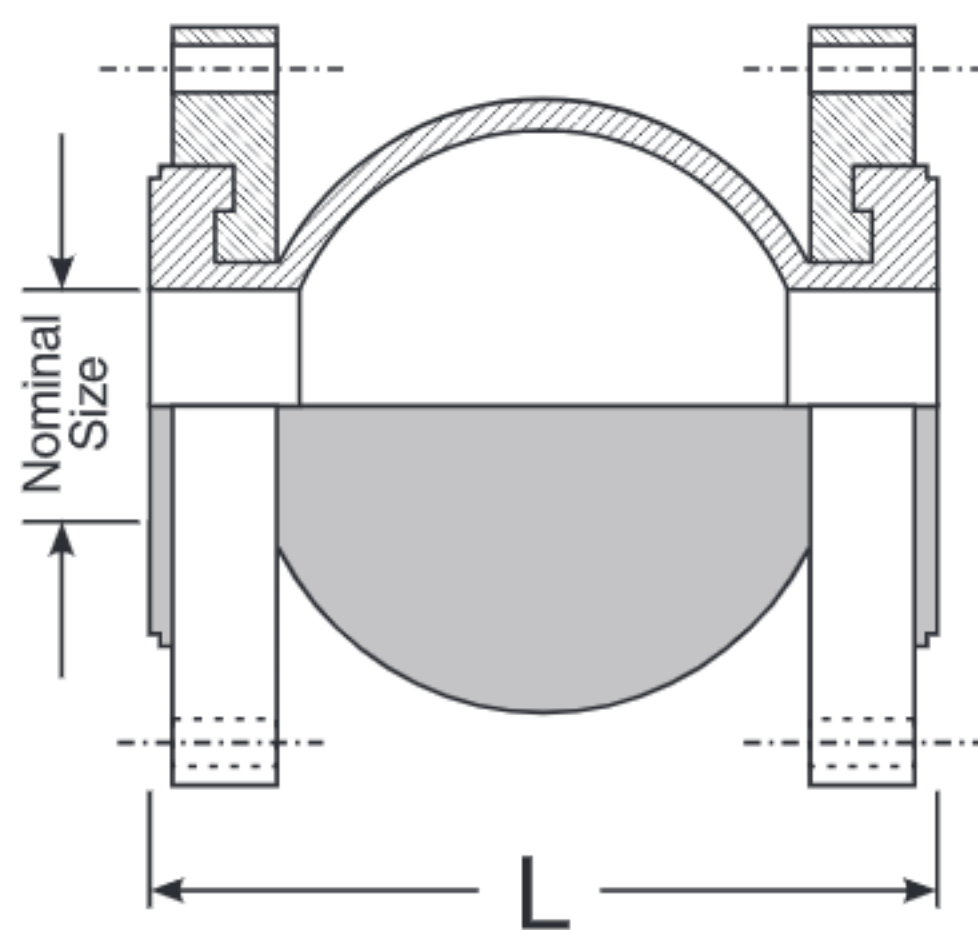

Part Number	Size (in)	Length (L - in)	Allowable Movement				Operating Conditions			
			Axial Compression (in)	Axial Elongation (in)	Transverse Deflection (in)	Angular Deflection (Degrees)	Max. Pressure (psi)	Max. Temp. (°F)	Vacuum (hg)	Weight Each (lbs)
HTSRF12x6	1 1/4	6	1/2	3/8	1/2	15	225	220	16	5.00
HTSRF15x6	1 1/2	6	1/2	3/8	1/2	15	225	220	16	6.10
HTSRF20x6	2	6	1/2	3/8	1/2	15	225	220	16	8.90
HTSRF25x6	2 1/2	6	1/2	3/8	1/2	15	225	220	16	12.30
HTSRF30x6	3	6	1/2	3/8	1/2	15	225	220	16	14.00
HTSRF40x6	4	6	5/8	3/8	1/2	15	225	220	16	18.30
HTSRF50x6	5	6	5/8	3/8	1/2	15	225	220	16	22.80
HTSRF60x6	6	6	5/8	3/8	1/2	15	225	220	16	26.80
HTSRF80x6	8	6	5/8	3/8	1/2	15	225	220	16	40.60
HTSRF100x8	10	8	3/4	1/2	3/4	15	225	220	16	56.60
HTSRF120x8	12	8	3/4	1/2	3/4	15	225	220	16	83.00

† **NOTE:** Not for use with oxidizing acids, esters, and keytones

Because we continually examine ways to improve our products, we reserve the right to alter specifications or discontinue products without prior notice.